

APP CRS 273°	Rwy Idg 4850
	TDZE 778
	Apt Elev 790

RNAV (GPS) RWY 27

BULT FLD (C56)

NA DME/DME RNP-0.3 NA. Visibility reduction by helicopters NA. Use Lansing Muni altimeter setting, when not received, use Chicago Midway Intl altimeter setting and increase all MDA 40 feet. Procedure NA at night.

MISSED APPROACH: Climb to 2600 direct RODJU and via 196° track to EON VORTAC and hold.

AWOS-AV 119.125	IGQ AWOS-3PT 124.925	CHICAGO CENTER 132.5 284.7	UNICOM 123.0 (CTAF)
---------------------------	--------------------------------	--------------------------------------	-------------------------------

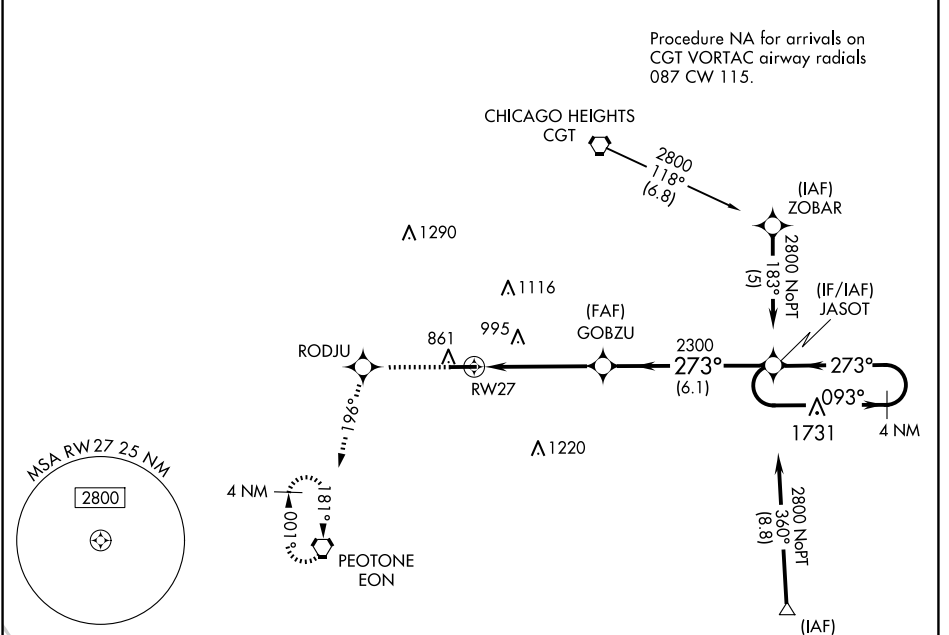

EC-3, 15 MAY 2025 to 12 JUN 2025

EC-3, 15 MAY 2025 to 12 JUN 2025

ELEV 790	TDZE 778
----------	----------

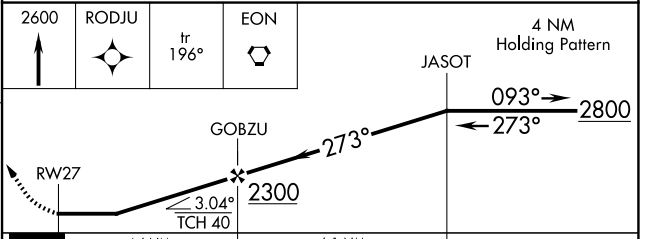
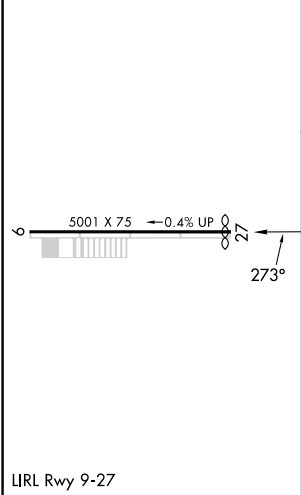

CATEGORY	A	B	C	D
LNAV MDA	1320-1	542 (600-1)	1320-1½ 542 (600-1½)	NA
CIRCLING	1320-1 530 (600-1)	1400-1 610 (700-1)	1400-1¾ 610 (700-1¾)	NA